

GROUND LIFT SCISSOR TABLE - EHLTG-5284-3-54

APPROX WEIGHT: 2683.89 lbs.
 DOES NOT INCLUDE WEIGHT OF POWER OR PACKAGING!!!

*** ANY ADDITIONS, DELETIONS, OR OMISSIONS MUST BE CORRECTED ON THIS DRAWING AS THIS DRAWING WILL BE CONSIDERED ALL INCLUSIVE ***

ALL GRAPHICS PROVIDED ARE FOR REFERENCE ONLY. IF CERTAIN DIMENSIONS ARE CRITICAL PLEASE VERIFY THOSE DIMENSIONS WITH YOUR SALESPERSON

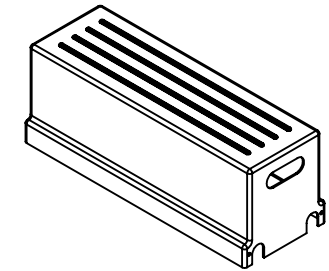
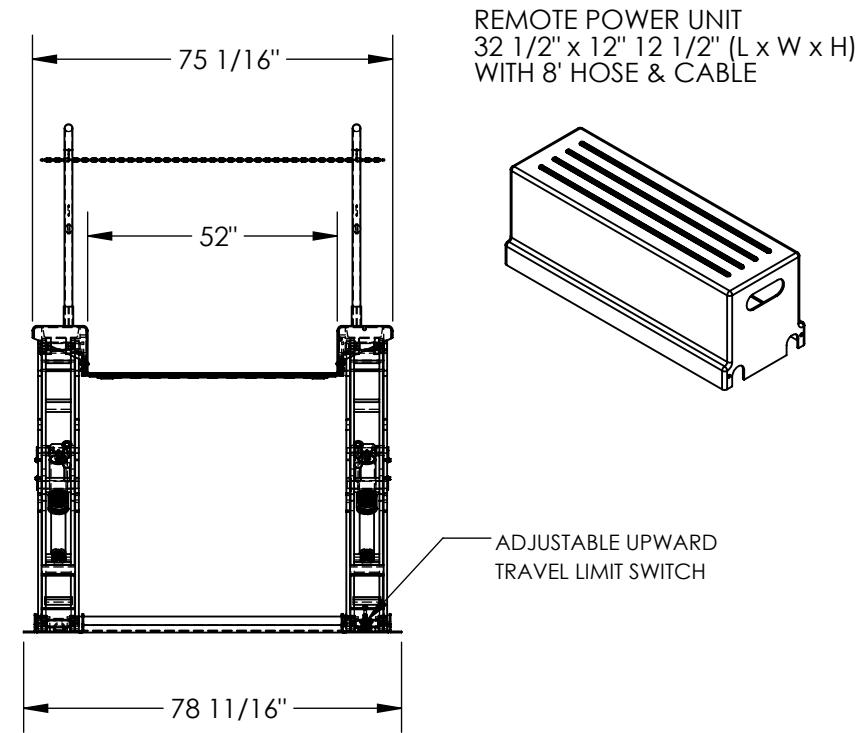
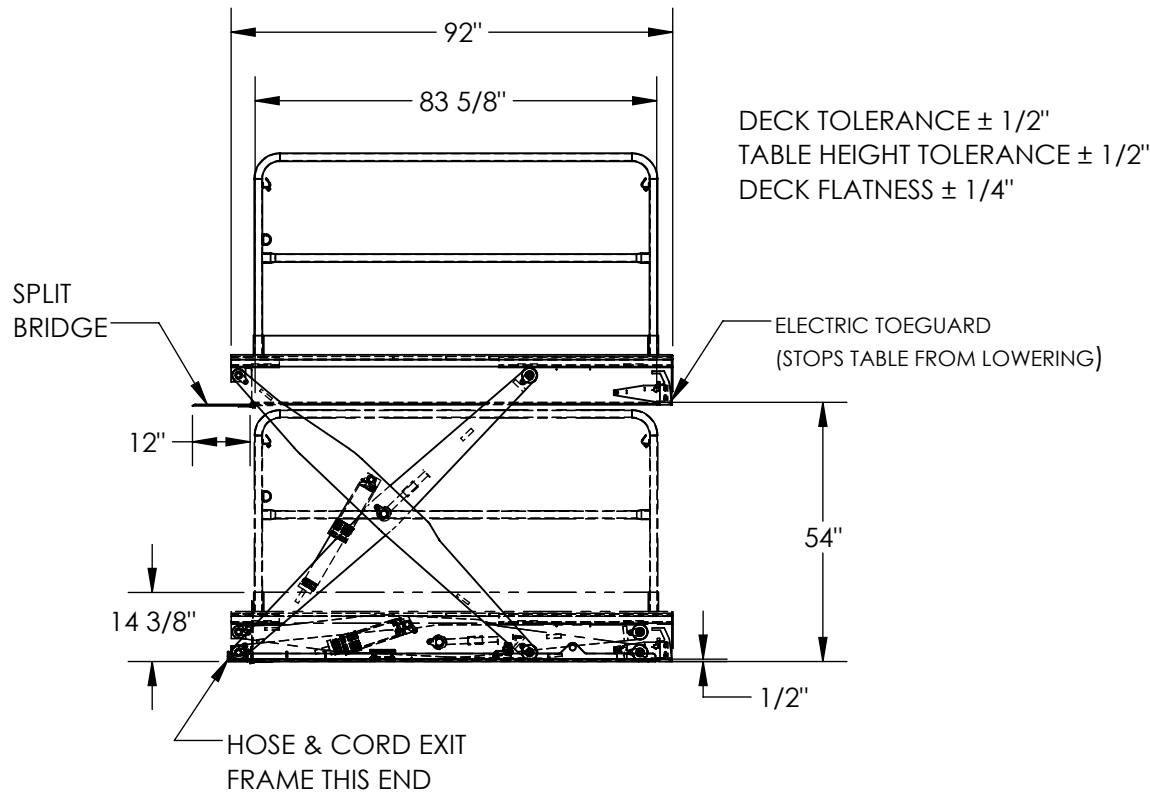

STANDARD FEATURES
 MODEL NUMBER IS EHLTG-5284-3-54
 OVERALL WIDTH IS 78 11/16"
 USABLE WIDTH IS 52"
 OVERALL LENGTH IS 92"
 USABLE LENGTH IS 83 5/8"
 RAISED HEIGHT IS 54"
 LOWERED HEIGHT IS 1/2"
 12" WIDE BY 52" LONG SLIT BRIDGE
 TABLE CAPACITY (EVENLY DISTRIBUTED) IS 3,000 LBS.
 EXTERNAL POWER UNIT
 NON-REMOVABLE TOE BOARDS
 SAFETY MAINTENANCE PROPS
 DISPLACEMENT STYLE CYLINDERS
 INSTALLED ROD DOWN
 EMERGENCY SAFETY STOP HYDRAULIC FUSES IN ALL CYLINDERS
 UNITS HAVE 2' TEST LEAD AND PIG TAIL
 CONTROL IS FOOT SWITCH, 2 PEDAL, NEMA 1 WITH MINIMUM USABLE 8' STRAIGHT CORD
 DURABLE LIQUID PAINT BLUE FINISH WITH TOUGH BAKED IN POWDER COATED YELLOW FINISH REMOVABLE HAND RAILS

PLEASE CIRCLE SPECIFICATIONS:

POWER	AC	DC (12V)	AIR/OIL
MOTOR VOLTAGE	115	208	230 460
DEDICATED CIRCUIT REQUIRED 60Hz			
MOTOR PHASE	SINGLE	THREE	
CONTROL	HAND	FOOT	

SPECIAL FEATURES
 NONE

DIMENSION TOLERANCE ± 1/4"

APPROVAL

I, THE UNDERSIGNED, AGREE THAT THE PRODUCT AS REPRESENTED SATISFIES DESIGN AND DIMENSION REQUIREMENTS. I ALSO ACKNOWLEDGE MY DUTY TO CONFIRM PRODUCT AND INSTALLATION COMPLIANCE WITH ALL APPLICABLE FEDERAL, STATE AND LOCAL REGULATIONS AND STANDARDS.
UNITS REQUIRING APPROVAL DRAWINGS OR MODIFIED ARE NON-RETURNABLE
 As drawn As marked

Signed: _____ Date: _____

Printed Name: _____

LEAD TIME WILL START UPON RECEIPT OF SIGNED APPROVAL DRAWING

DISTRIBUTOR'S NAME:		P.O.#
VESTIL MANUFACTURING		X
DRAWN BY:	DATE:	W.O.#
JWW	8/15/19	X
REFERENCE:	SCALE:	SALES:
X	1:40	X
QUOTED LEAD TIME:	QUOTE #	FILE NAME:
X	X	04-007-114